



QUALITY... PLAIN & SIMPLE®

## Ford AOD Hi-Tech Kickdown Kit Installation Instructions

### General Installation Notes:

Please read these instructions completely before beginning the installation. If you have any questions please call.

Before beginning the installation, disconnect the negative battery cable and use wheel chocks to block the vehicle's wheels. Do not attempt to install this product while the engine is running.

Make sure the engine, transmission, body and frame are properly grounded. We recommend applying anti-seize lubricant to all aluminum threads before final assembly.

**NOTE:** The AOD Kickdown Kit is used to actuate the Throttle Valve (T.V.) within the transmission. Some of the components contained in this kit are also used in other applications that have a kickdown cable, and the word "kickdown" will be used in the name of the component.

This Lokar Kickdown Kit is designed to be installed with a Lokar Stainless Steel Carburetor Bracket and Springs, part # SRK-4000 (not included). The Lokar T.V. Cable is designed to be cut-to-fit.

Refer to Fig. 1 and Fig. 2 for the component names.

**Step 1:** Remove any and all existing throttle valve (T.V.) linkage parts.

**Step 2:** Remove the cable end stop, kickdown throttle body fitting, and T.V. cable adjuster from the engine end of the new Lokar T.V. cable. If the cable housing is braided stainless steel, **DO NOT remove the ferrule from the cable housing!** Leave the kickdown mounting bracket on the T.V. cable adjuster. Remove the inner wire and the return spring from the T.V. cable housing, and remove the T.V. lever from the inner wire. Remove the kickdown extender and the trans cable bracket from the transmission end of the T.V. cable housing.

**Step 3:** There are two different locations the trans cable bracket can be mounted onto the transmission, depending on which direction the gear selector trans arm on the transmission is pointing. This will also determine how the T.V. lever will be positioned on the transmission.

If the gear selector trans arm is pointing up, then the T.V. lever will point down. In this case, the trans cable bracket will be installed onto the second transmission pan bolt behind the gear selector shaft.

# Ford AOD Hi-Tech Kickdown Kit Installation Instructions

Building American Quality... With A Lifetime Warranty!®

TOLL FREE 1-877-469-7440 • tech@lokar.com • www.lokar.com

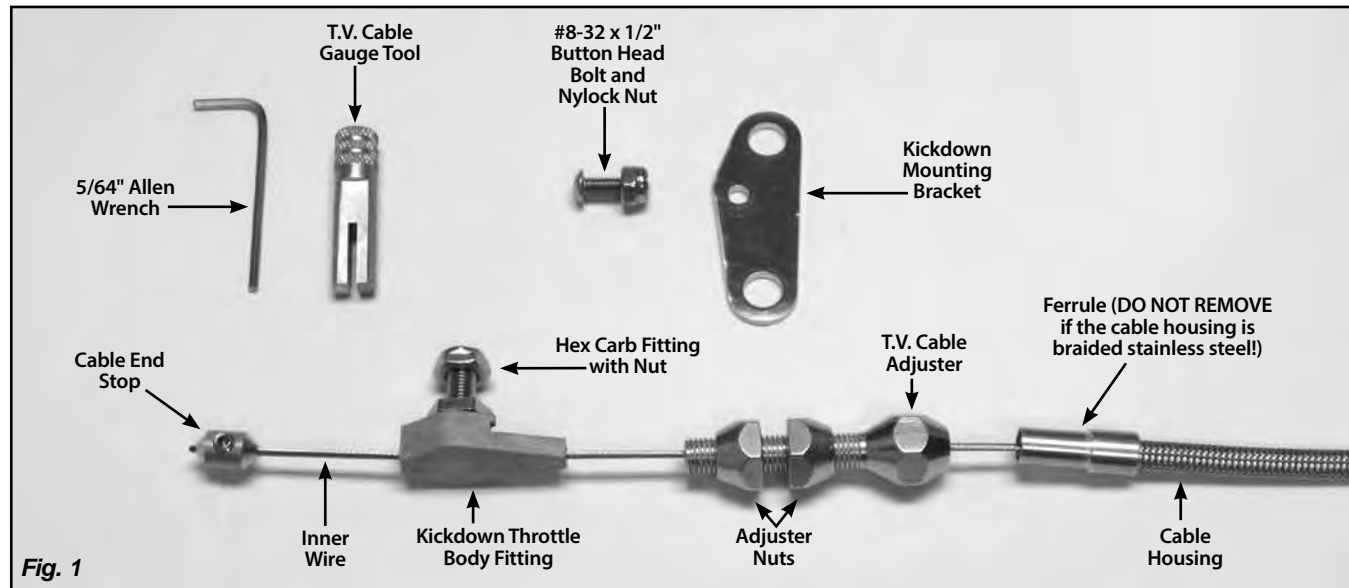


Fig. 1

**Step 3: (Continued)** Remove the original pan bolt. Install the supplied M8 x 40mm bolt with the supplied lock washer, flat washer, trans cable bracket, and 3/8" thick spacer installed onto the bolt in that order. The spacer will keep the T.V. cable in line with the T.V. lever. Make sure the vertical part of the trans cable bracket is positioned to the rear of the pan bolt as shown in Fig. 3.

If the gear selector trans arm is pointing down, then the T.V. lever will point up. In this case, the 3/8" thick spacer and the trans cable bracket will be installed onto the top side of the transmission bellhousing boss. Install the supplied M8 x 40mm bolt and nylock nut with the trans cable bracket on the very top, and the 3/8" thick spacer between the trans cable bracket and the transmission bellhousing boss. The flat washer will go underneath the bellhousing boss, and the lock washer is not required. The spacer will keep the T.V. cable in line with the T.V. lever. Make sure the vertical part of the trans cable bracket is positioned to the rear of the M8 bolt as shown in Fig. 4.

**Step 4:** Install the T.V. lever and nut onto the threaded T.V. shaft in the center of the gear selector shaft.

**Step 5:** Install the threaded end of the T.V. cable housing into the trans cable bracket, and thread the kickdown extender onto the T.V. cable housing.

**Step 6:** If the throttle cable has already been installed, disconnect the throttle cable from the carburetor. If the engine already has a Lokar Carburetor Bracket installed, leave the bracket in place but remove the throttle cable adjuster from it.

**Step 6: (Continued)** If the engine does not already have a Lokar Carburetor Bracket installed, install one now, following the installation instructions that are provided with the Lokar Carburetor Bracket.

**Step 7:** The kickdown mounting bracket mounts onto the back side of the Lokar Carburetor Bracket. The throttle cable adjuster will pass through the top holes in both the new kickdown mounting bracket **AND** the carburetor bracket.

Position the kickdown mounting bracket behind the carburetor bracket. The large holes at the top of both brackets should be aligned with each other, and the small holes near the center of the two brackets should also be aligned with each other. The T.V. cable adjuster should be offset towards the left side of the vehicle.

Attach the kickdown mounting bracket to the back of the carburetor bracket using the supplied #8-32 x 1/2" button head bolt and nylock nut through the small diameter center holes in both brackets. Do not tighten yet.

Insert the throttle cable adjuster (with the rear nut still installed) from the rear through the top holes in both brackets. Position the throttle cable adjuster so that the bracket is roughly centered in the threaded part of the cable adjuster. Install the front adjuster nut.

Tighten the throttle cable adjuster nuts, the button head bolt and nut, and the T.V. cable adjuster nuts. Fig. 5

## Ford AOD Hi-Tech Kickdown Kit Installation Instructions

**Step 8:** It will be necessary to shorten the new T.V. cable assembly. Route the cable housing up to the T.V. cable adjuster, and mark the cable housing where it lines up with the T.V. cable adjuster. Then add 1" (further away from the transmission) and mark your cut line at that spot.

If the cable housing is braided stainless steel, slide the ferrule down the housing towards the transmission and past your cut line, away from the end that is being cut.

**DO NOT remove the ferrule from the braided stainless steel housing!** If the cable housing is black universal, remove the ferrule.

**Make sure that the inner wire is removed from the cable housing.** If the T.V. cable has the braided stainless steel housing, wrap tape around the area to be cut and use a cutoff wheel or fine-toothed hacksaw to cut the cable housing at your cut line. If the T.V. cable has the black universal housing, cut the cable housing at your cut line using heavy duty 8" diagonal cutting pliers or a hacksaw. Lokar recommends Klein brand Diagonal Cutting Pliers, # D2000-28 available at The Home Depot or through W. W. Grainger, part # 4A838.

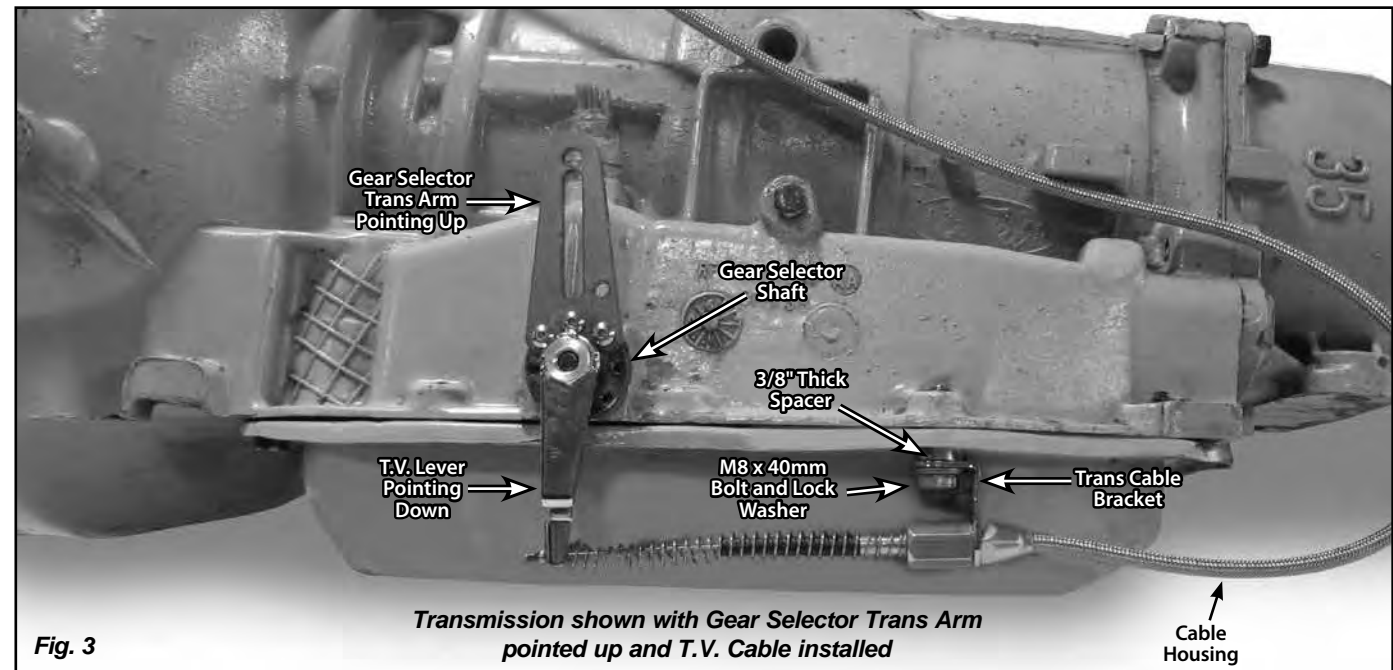
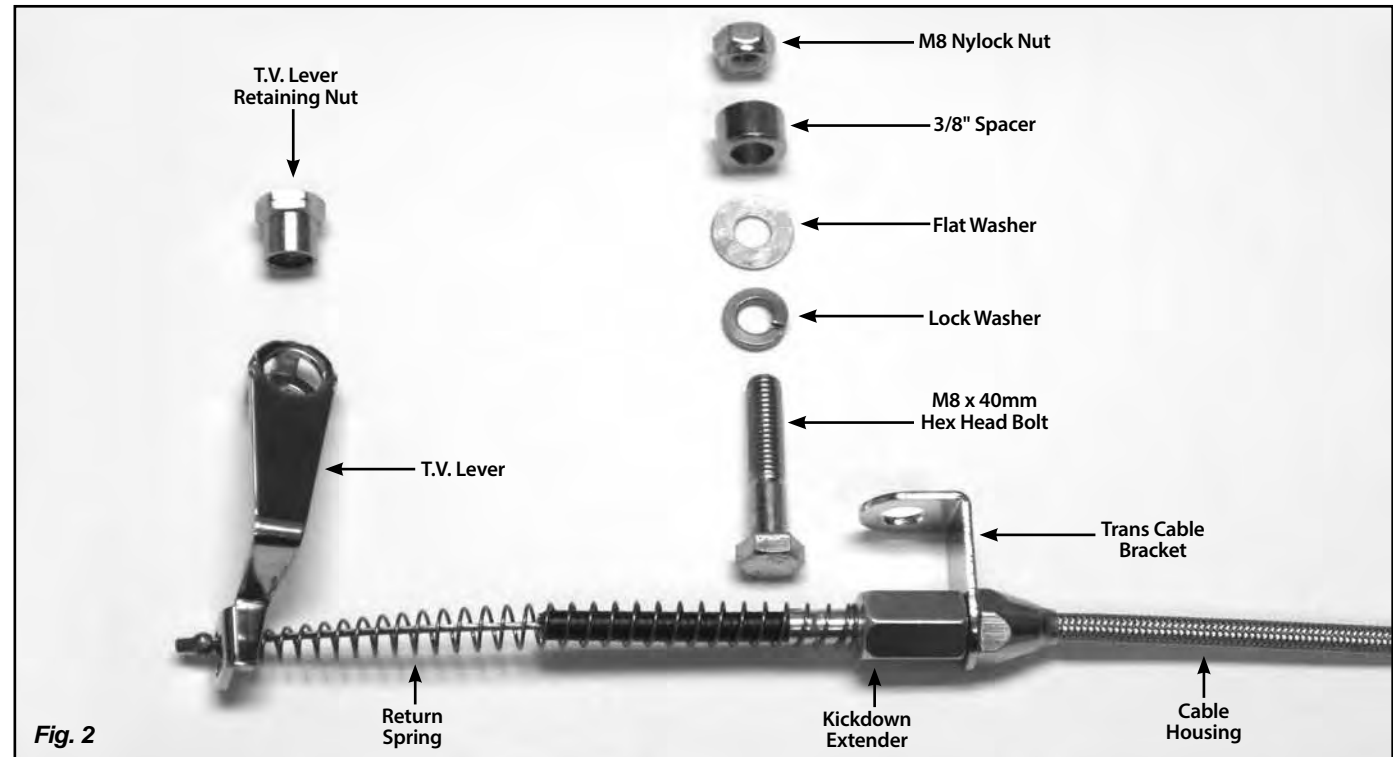
After cutting the cable housing, put the ferrule back in place at the end of the cable housing. Insert the cable housing and ferrule into the T.V. cable adjuster.

**Step 9:** The tear drop will be attached to the carburetor throttle arm by the hex carb fitting. Separate the hex carb fitting from the kickdown throttle body fitting as shown in **Fig. 6**. Install the tear drop with the hex carb fitting and the 1/4"-28 nylock jam nut onto the carburetor throttle arm. Hook the springs to the tear drop and tighten the nylock jam nut. **Fig. 7** Then, back the nut off just enough so that the tear drop can rotate freely.

Install the inner wire by starting at the T.V. lever on the transmission. There are two holes in the T.V. arm that the inner wire can be inserted into. **Fig. 8** If using an Edelbrock or similarly designed carburetor, install the cable in the hole closest to where the arm is mounted to the shaft (hole "A"). If using a Holley or similarly designed carburetor, install the cable in the hole closest to the end of the T.V. arm (hole "B").

Feed the inner wire through the T.V. lever, return spring, kickdown extender, cable housing and the T.V. cable adjuster up to the carburetor. Slide the kickdown throttle body fitting and the cable end stop onto the inner wire, and snap the kickdown throttle body fitting onto the hex carb fitting. With the carburetor in its normal, warm idle, closed throttle position, slide the cable end stop up to the kickdown throttle body fitting and lightly tighten the set screw with the 5/64" Allen wrench supplied in the kit.

After the installation is complete, make sure that the throttle will reach wide open and that the T.V. lever does not bottom out. Check this by holding the throttle in the wide open position and pushing the T.V. lever in the same direction it is being pulled by the cable. The T.V. lever should be able to move a small amount; this will ensure that the T.V. cable will not over pull.



# Ford AOD Hi-Tech Kickdown Kit Installation Instructions

## T.V. Cable Pressure Adjustment

**WARNING:** Failure to perform the following T.V. Pressure Adjustment procedure may cause your transmission to fail prematurely, possibly within only the first few miles!

**NOTE:** Adjustment of the T.V. cable must be done with the carburetor off of fast idle and the engine at normal operating temperature. **If the idle speed setting on the carburetor is ever changed, the T.V. cable adjustment will need to be re-checked and adjusted.**

**Step 10:** On the passenger side of the transmission near the tailhousing, you will find three test ports. The TV test port is the one in the middle. **Fig. 9** Remove the block off plug from the T.V. test port, and connect an oil pressure gauge with hose (not included) using a 1/8" NPT fitting. The oil pressure gauge needs to be capable of handling at least 60 PSI and be marked with individual PSI readings all the way down to zero.

**Step 11:** Pull forward on the cable end stop at the engine end of the T.V. cable in order to create some clearance between the cable end stop and the kickdown throttle body fitting. Insert the slotted end of the supplied T.V. cable gauge tool between the cable end stop and the kickdown throttle body fitting so that the T.V. cable inner wire is inside the slot on the tool. **Fig. 10**

**Step 12:** Operate the engine until it reaches normal operating temperature. The transmission fluid temperature should be approximately 100°-150° F (38°-70° C). Do not perform the pressure adjustment procedure if the transmission fluid is cold or is too hot to touch.

**Step 13:** Set the parking brake and place the shifter in **NEUTRAL**. With the T.V. cable gauge tool in place and the engine at warm idle, the T.V. pressure should be 35 PSI.

**Note: DO NOT** check or set T.V. pressure in PARK, the pressure is different!

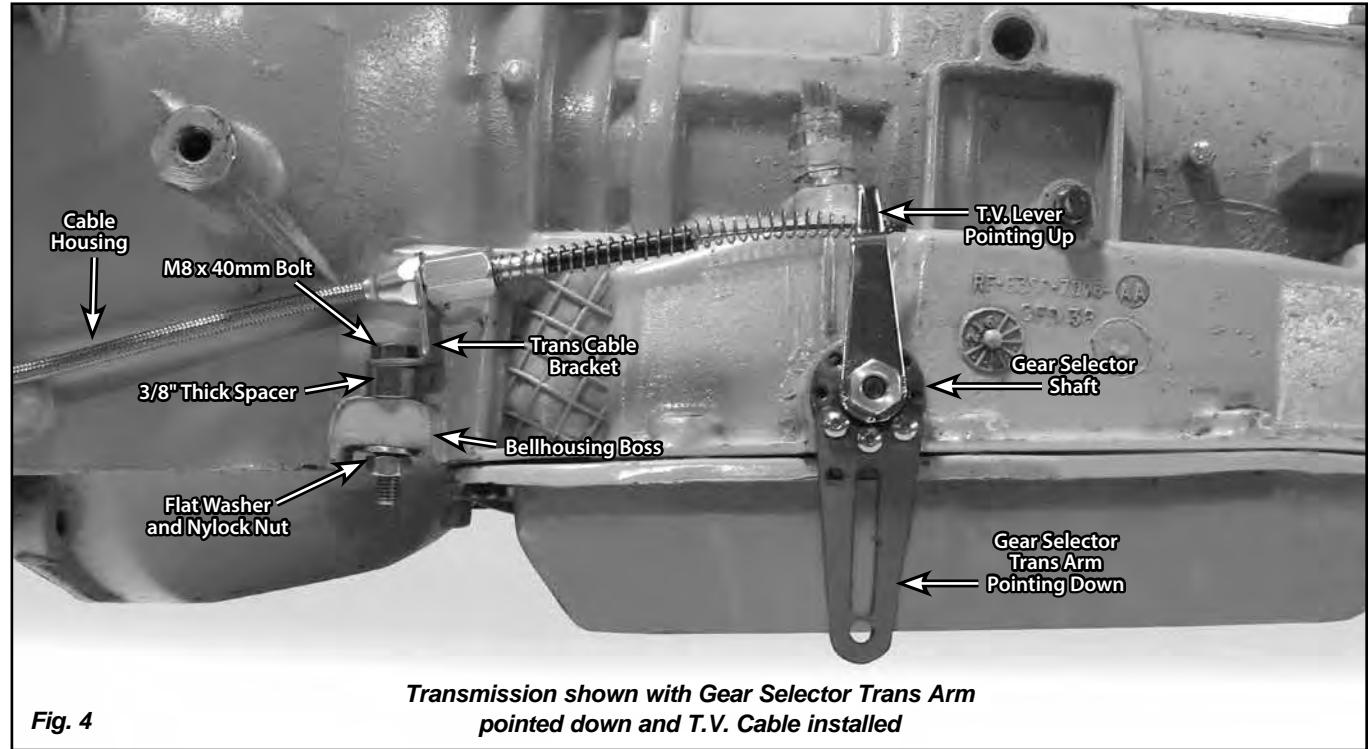
**Step 14:** Adjust as needed to get the T.V. pressure to 35 PSI. Make major adjustments by moving the cable end stop one direction or the other, and make minor adjustments at the two nuts on the T.V. cable adjuster.

**Step 15:** Once you have the cable adjusted so that the pressure gauge reads 35 PSI with the T.V. cable gauge tool inserted, remove the T.V. cable gauge tool.

**Step 16:** Allow the T.V. cable to return to its normal idle position. With the engine still idling in **NEUTRAL**, T.V. pressure must be at or near zero. If not, reinstall the T.V. cable gauge tool. Repeat steps 11 through 15, but set T.V. pressure to a value between 30 PSI and 34 PSI. Remove the T.V. cable gauge tool and recheck T.V. pressure to determine if it is at or near zero.

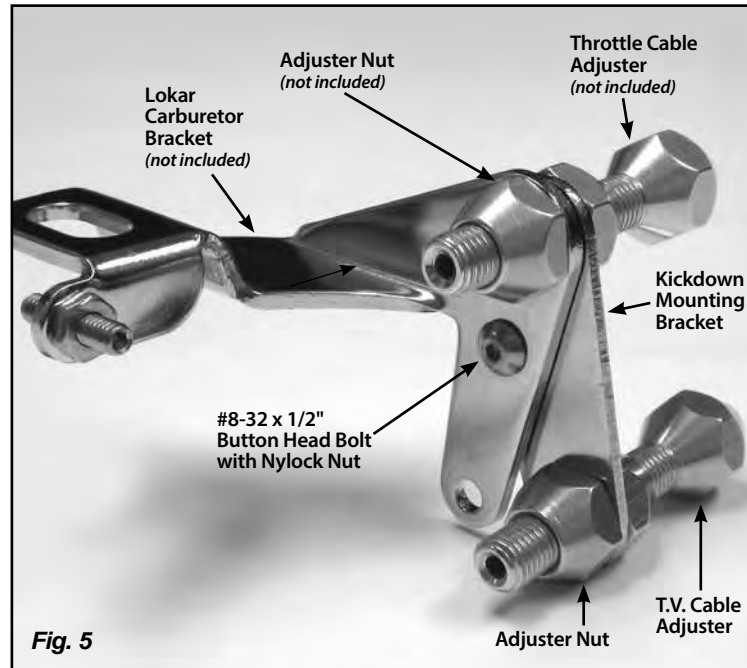
**Step 17:** Once you have achieved the pressures described above, with the engine still idling and the transmission in **NEUTRAL**, watch the pressure gauge while you slowly begin to open the throttle. The T.V. pressure should begin to rise immediately when the throttle begins to move. If not, then remove any slack in the T.V. cable until the pressure does begin to rise immediately when the throttle is moved. Then, repeat **Steps 11-17. If there is slack in the T.V. cable, it can damage your transmission!**

**Step 18:** Disconnect the pressure gauge and re-install the plug in the T.V. test port.

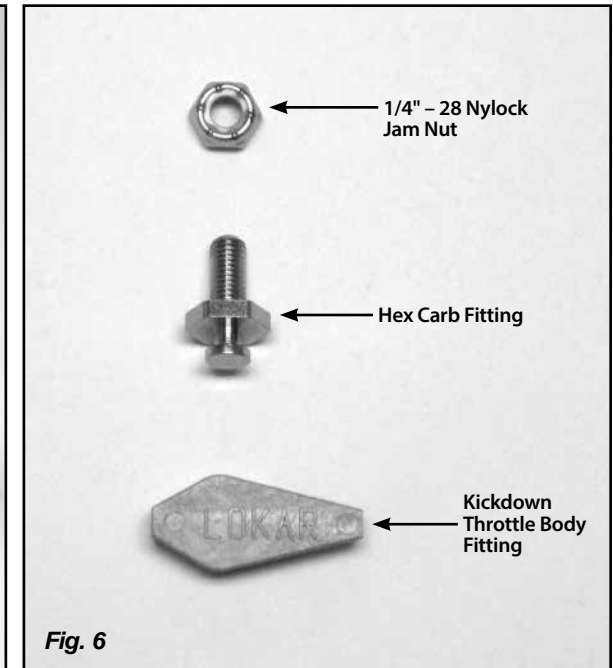


**Fig. 4**

**Transmission shown with Gear Selector Trans Arm pointed down and T.V. Cable installed**



**Fig. 5**



**Fig. 6**

# Ford AOD Hi-Tech Kickdown Kit Installation Instructions

